

Throttle/check valve Z2FS 6

NS 6 | p_{max} 35 MPa | Q_{max} 60 dm³/min | WK 421 060



DATA SHEET - OPERATION MANUAL

APPLICATION

Throttle/check valve type **Z2FS6...** is used to control main flow rate (or pilot flow rate) in one direction and to allow free flow in the opposite direction. The valve may be designed as double version (valve function is realized in two ports **A** and **B**) or single version (valve function is realized in one port **A** or **B**). The valve is applied to sandwich plate mounting. Generally valve is fitted between subplate and directional valve of the same nominal size and is used to limit main flow rate (to control the speed of an actuator movement). For pilot operated directional valves the valve is applied for switching time adjustment (to limit pilot flow rate). In this case it is fitted between the main and the pilot directional valve.

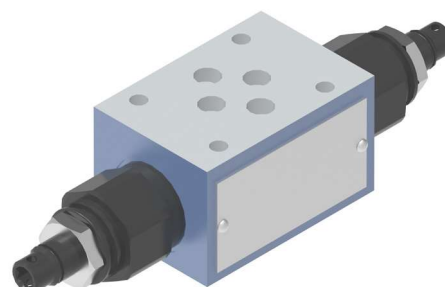

version **Z2FS6-44/2**

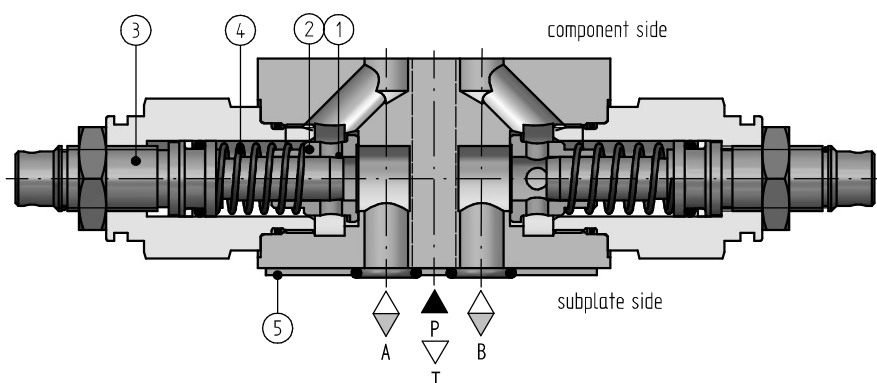

DESCRIPTION OF OPERATION

Hydraulic fluid from directional valve via port **A** (or **B**) flows to actuator through throttling point **1**. At the same time the fluid under operating pressure acts on poppet **2** from a throttle screw **3** side. Poppet **2** is held in throttle position by both spring **4** and hydrostatic force. Hydraulic fluid flowing back from actuator through port **B** (or **A**) displaces poppet **2** against the spring **4** in the direction of throttle screw **3** and enables the unobstructed flow as check valve. Throttle rate can be adjusted by means of throttle screw **3**. Depending on the way the valve is mounted in relations to the seal ring plate **5** throttling effect can be achieved either in the supply (option showed in the drawing) or discharge of actuator (by 180° horizontal rotation of the valve).

EXAMPLES OF APPLICATION

flow throttling in the supply of the actuator

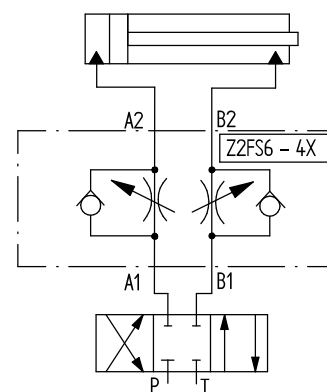

flow throttling in the discharge of the actuator - valve mounted in 180° rotated position

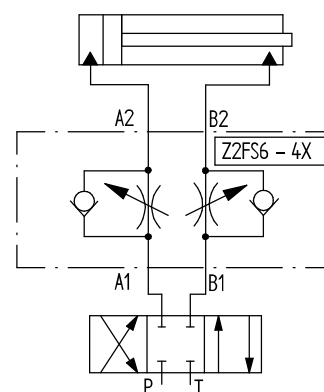

TECHNICAL PARAMETERS

hydraulic fluid	mineral oil	ambient temperature range	-20 ÷ 70 °C
required fluid cleanliness class	ISO 4406 class 20/18/15	max. working pressure	35 MPa
nominal fluid viscosity	37 mm ² /s at temp. 55 °C	cracking pressure	0,06 MPa
viscosity range	2,8 ÷ 380 mm ² /s	max. flow	60 dm ³ /min
fluid temperature range (in tank)	max. -20 ÷ 70 °C; rec. 40 ÷ 55 °C	weight	0,9 kg

assembly and operation requirements at: www.operating-conditions.ponar.pl

HYDRAULIC DIAGRAMS

double version Z2FS6.../...

supply throttling
component side

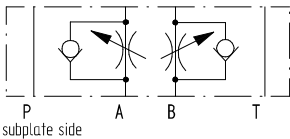

discharge throttling
component side

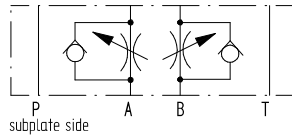

single version Z2FS6.../A...

supply throttling
component side

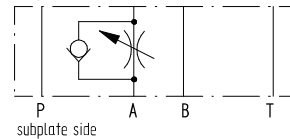

discharge throttling
component side

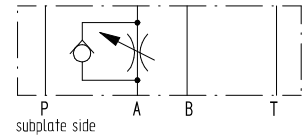

single version Z2FS6.../B...

supply throttling
component side

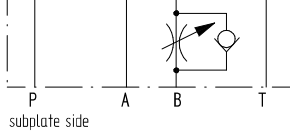

discharge throttling
component side

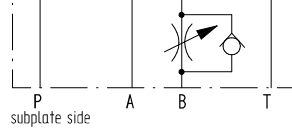

PERFORMANCE CURVES

for fluid viscosity $\nu = 41 \text{ mm}^2/\text{s}$ and temp. $t = 50 \text{ }^\circ\text{C}$

characteristic curves $\Delta p(Q)$ for various throttle settings

standard version

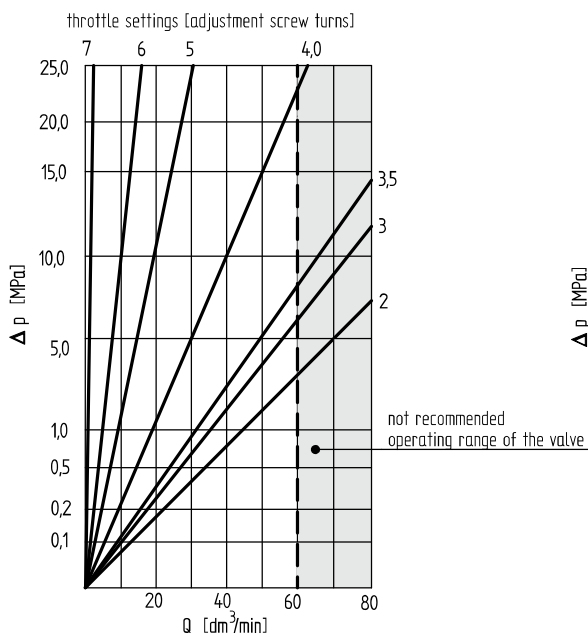

version 40 (up to 40 dm³/min)

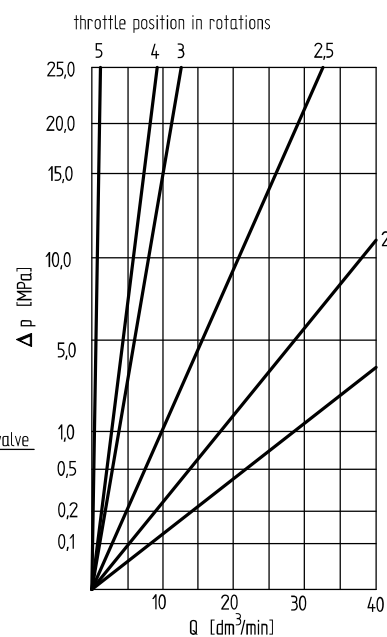

version 10 (up to 10 dm³/min)

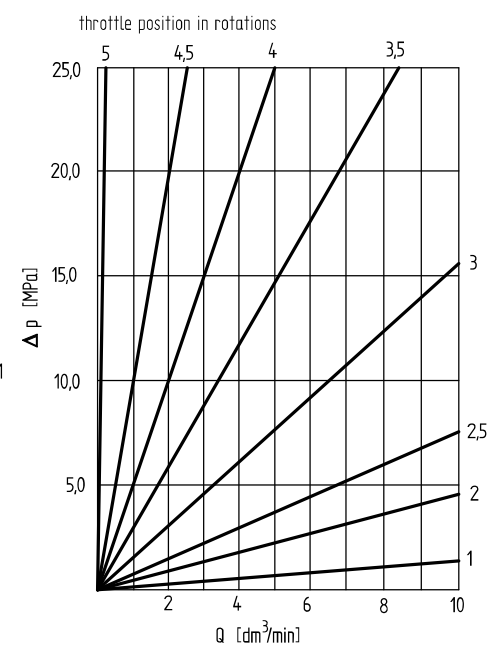

flow resistance curve $\Delta p(Q)$ via check valve - throttle closed

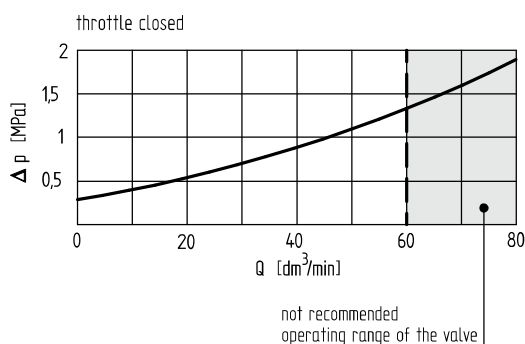

OVERALL AND CONNECTION DIMENSIONS

double version Z2FS6...

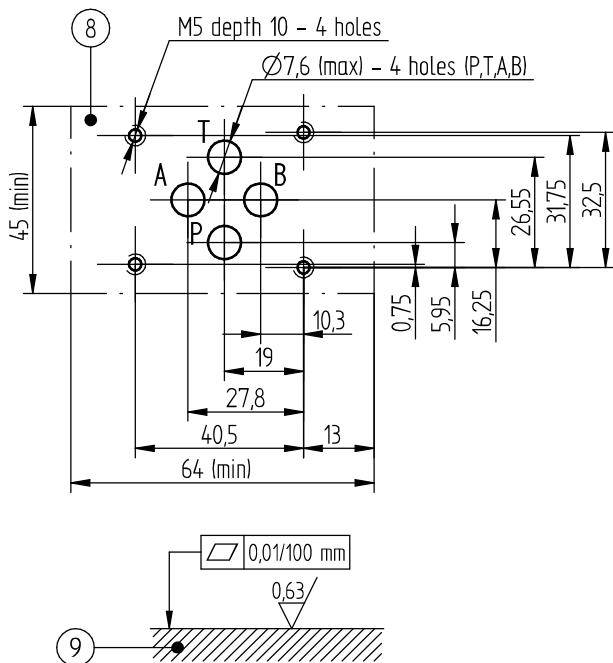
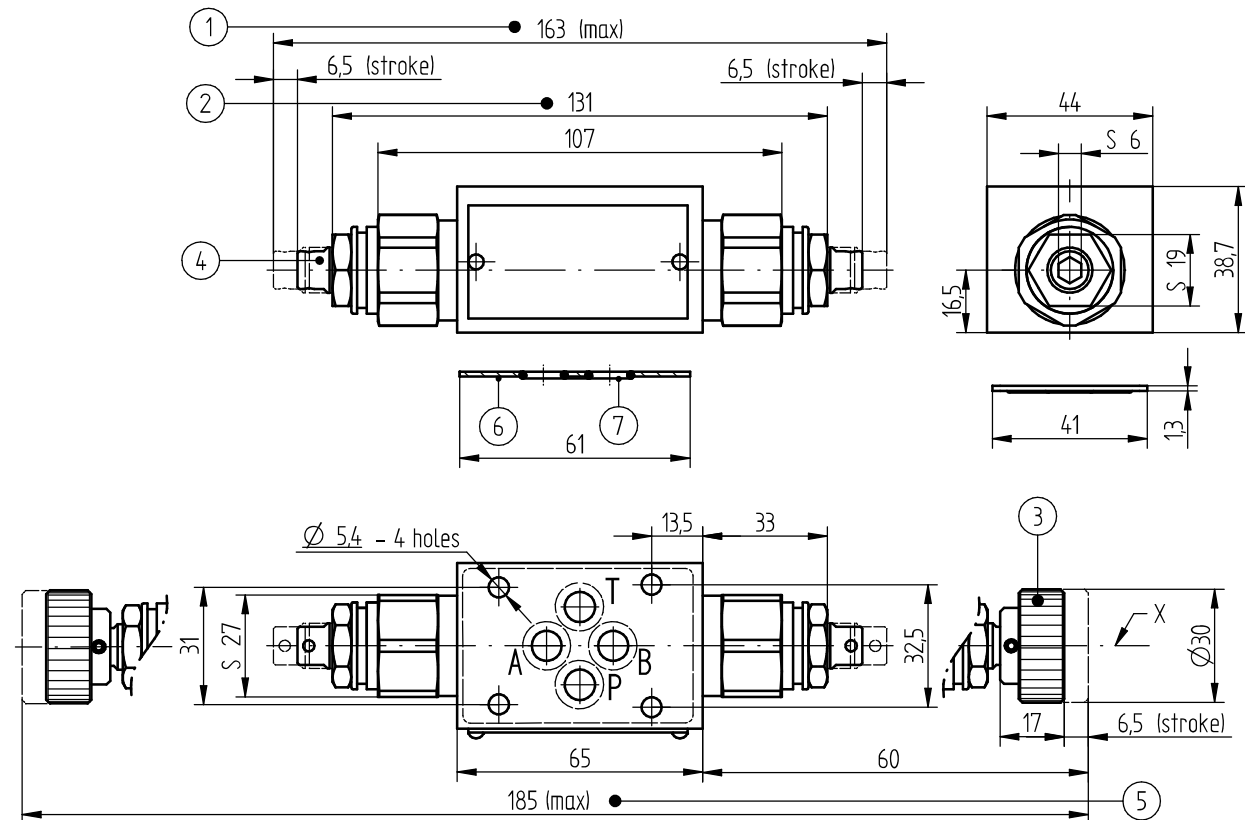

- 1,2. overall dimensions for the valve version Z2FS6.../2... with throttling effect in ports **A, B**
3. adjusting element **1** (hand knob); rotation to the right - increasing flow throttling effect; rotation to the left - decreasing flow throttling effect
4. adjusting element **2** - set screw
5. overall dimensions for the valve version Z2FS6.../1... with throttling effect in ports **A, B**
6. seal ring plate - enables to arrange throttling effect in the supply or in the discharge by changing the way in which the valve is mounted in relation to the plate - rotation of valve about the axis X by 180° (see examples on page 1)
7. o-ring **9,2 × 1,8** - 4 pcs/set (**P, T, A, B**)
8. porting pattern of the subplate compliant with standards:
 - **CETOP RP 121H** - designation CETOP 4.2-4-03 (nominal size CETOP 03)
 - **ISO 4401** - designation **ISO 4401-03-02-0-94**
9. required surface quality of the valve contact surface

OVERALL AND CONNECTION DIMENSIONS

single version Z2FS6A..., Z2FS6B...

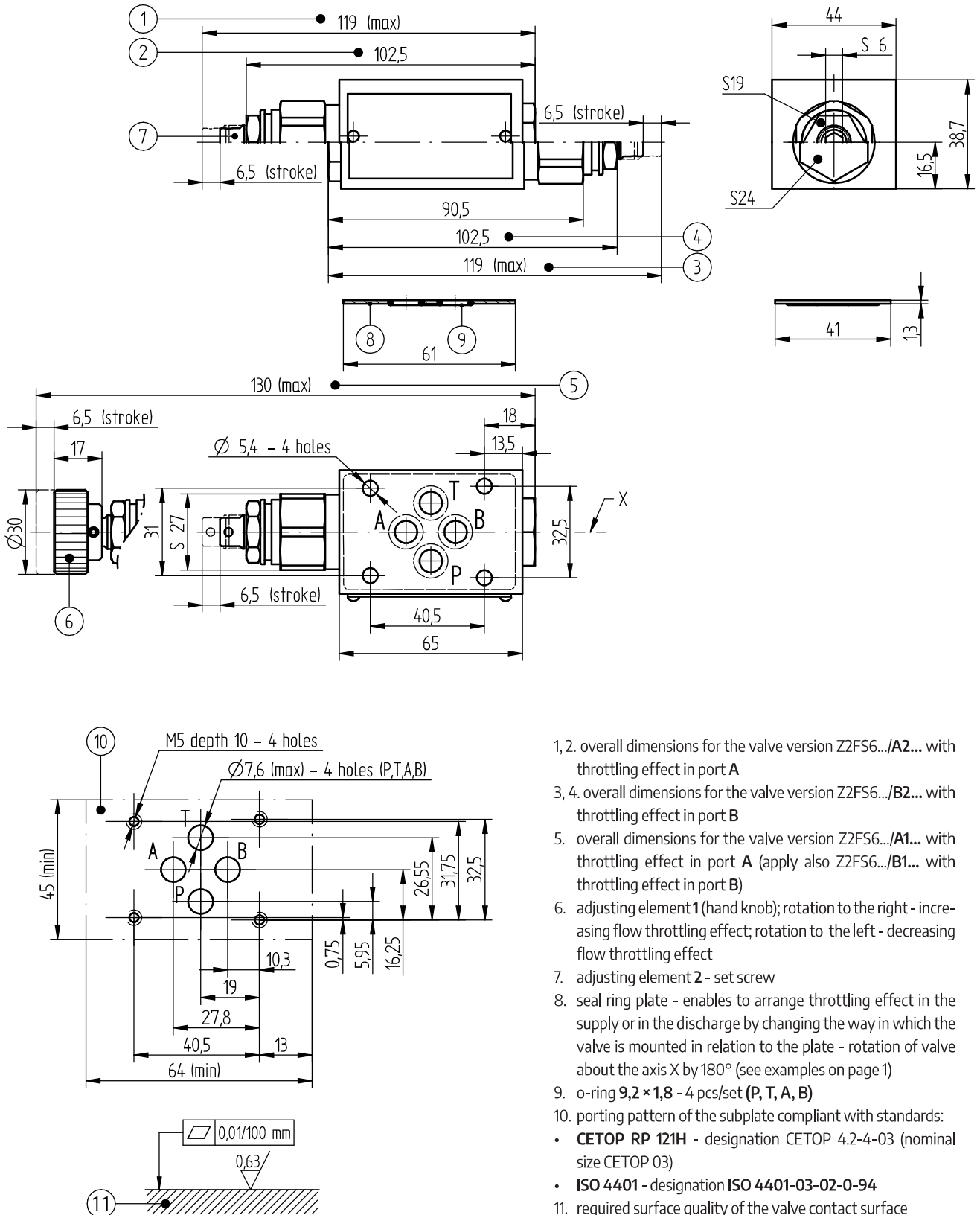

- 1, 2. overall dimensions for the valve version Z2FS6.../A2... with throttling effect in port A
- 3, 4. overall dimensions for the valve version Z2FS6.../B2... with throttling effect in port B
5. overall dimensions for the valve version Z2FS6.../A1... with throttling effect in port A (apply also Z2FS6.../B1... with throttling effect in port B)
6. adjusting element 1 (hand knob); rotation to the right - increasing flow throttling effect; rotation to the left - decreasing flow throttling effect
7. adjusting element 2 - set screw
8. seal ring plate - enables to arrange throttling effect in the supply or in the discharge by changing the way in which the valve is mounted in relation to the plate - rotation of valve about the axis X by 180° (see examples on page 1)
9. o-ring 9,2 × 1,8 - 4 pcs/set (P, T, A, B)
10. porting pattern of the subplate compliant with standards:
 - CETOP RP 121H - designation CETOP 4.2-4-03 (nominal size CETOP 03)
 - ISO 4401 - designation ISO 4401-03-02-0-94
11. required surface quality of the valve contact surface

HOW TO ORDER

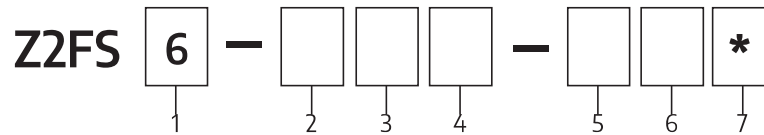

1 nominal size (NS)

NS6 = 6

2 series number

series 42 = 42

(40-49) connection and installation dimensions unchanged

3 throttle location (hydr. schemes page 2)

throttle valves side A and B = Ø

throttle valve side A = A

throttle valve side B = B

4 adjustment element

hand knob = 1

set screw with internal hexagon = 2

5 version (characteristics page 2)

standard = Ø

up to 40 dm³/min = 40

up to 10 dm³/min = 10

6 sealing

NBR (for fluids on mineral oil base) = Ø

FKM (for fluids on phosphate ester base) = V

7 further requirements = *

(to be agreed upon with the Manufacturer)

Ø indicates that the box should be left blank. The **symbols in bold** are the preferred versions available in short delivery time.

Coding example: **Z2FS6-42/2**

SUBPLATES AND MOUNTING SCREWS

Subplates should be ordered according to data sheet **WK 496 480**: Subplates and mounting screws for mounting the valve **M5 × L*** - 10,9 acc. to **PN - EN ISO 4762 (PN/M-82302)** 4 pcs/set **delivered on separate order**. Tightening torque of screws **M_d = 9 Nm**.

G 341/01 - threaded connection G ¼

G 342/01 - threaded connection G ⅜

G 502/01 - threaded connection G ½

NOTE:

(*) - required length of the screws L is related to type and the number of hydraulic components mounted under and over the sandwich plate valve

CONTACT

PONAR Wadowice S.A.
ul. Wojska Polskiego 29
34-100 Wadowice

tel. +48 33 488 21 00
www.ponar-wadowice.pl