

MM32CP

PRODUCT FEATURE SUMMARY

DATE: 07.03.2024

Username: Evelin Badic

MODEL TYPE: MM32CP

CNSORDERNO (Order number)	MM32CP
AO (Adjustment Option)	omit: without valve
MF (Mounting Flange)	omit: Three bolts mount
PT (Port type)	omit: Rear ports
DC (Displacement code)	32: 31,8 cm ³ /rev [1.93 in ³ /rev]
SE (Shaft Extensions)	C: ø16 straight, Parallel key A5x5x16 DIN6885
P (Ports)	omit: BSPP (ISO 228)
LC (Line to control)	-
VPR (Valve Rated Pressurebar)	-
SFMS (Special Features Measure speed)	omit: no special features
SFGWS (Special Features of gear wheel set)	omit: no special features
SFDR (Special Features - Direction of rotation)	omit: Standard
OP (Option (Paint))	P: Paint
INFO (Info)	PDF catalog
L (mm)	114
L1 (mm)	13.5

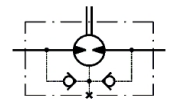

DATA SHEET

Type	
Displacement, cm³/rev [in³/rev]	31,8[1.93]
Max. Speed, [RPM]	cont.
	630
	Int.*
	790
Max. Torque, daNm [lb-in]	cont.
	4,0 [375]
	Int.*
	5,7 [506]
Max. Output, kW [HP]	cont.
	2,4 [3.3]
	Int.*
	3,2 [4.3]
Max. Pressure Drop, bar [PSI]	cont.
	105 [1500]
	Int.*
	140 [2030]
Max. Oil Flow, lpm [GPM]	cont.
	20 [5.5]
	Int.*
	25 [6.6]

Type	
Max. Inlet Pressure, bar [PSI]	cont.
	140 [2030]
	Int.*
	175 [2540]
	peak**
	225 [3260]
Max. Return Pressure with Drain Line bar [PSI]	cont.
	140 [2030]
	Int.*
	175 [2540]
	peak**
	225 [3260]
Pressure with Unloaded Shaft, bar [PSI]	
	4 [60]
Min Starting Torque, daNm [lb-in]	at max. press. drop cont.
	3,4 [300]
	at max. press. drop Int.*
	4,8 [425]
Min. Speed***, [RPM]	30
Weight, kg [lb]	2,2 [4.85]

* Intermittent operation: the permissible values may occur for max. 10% of every minute.

** Peak load: the permissible values may occur for max. 1% of every minute.

*** For speeds lower than given, consult factory or your regional manager.

- Intermittent speed and intermittent pressure drop must not occur simultaneously.
- Recommended filtration is per ISO cleanliness code 20/16. A nominal filtration of 25 micron or better.
- Recommend using a premium quality, anti-wear type mineral based hydraulic oil HLP(DIN51524) or HM (ISO 6743/4). If using synthetic fluids consult the factory for alternative seal materials.
- Recommended minimum oil viscosity 13 mm²/s [70 SUS] at 50°C [122°F].
- Recommended maximum system operating temperature is 82°C [180°F].
- To assure optimum motor life fill with fluid prior to loading and run at moderate load and speed for 10-15 minutes.

MM32CP

3d generated view

To see model in 3D you should use Acrobat Reader with enable 3D view

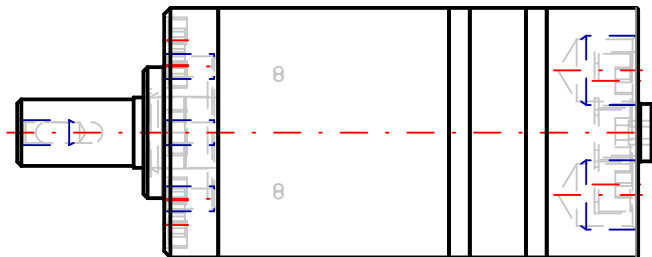
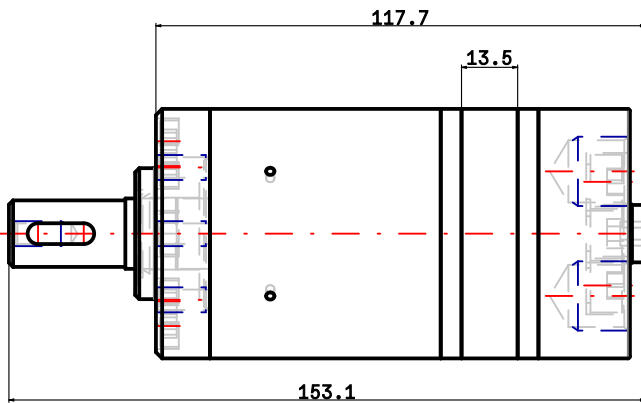
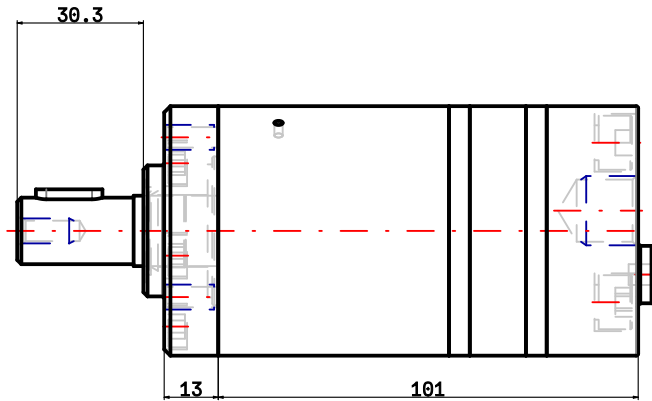
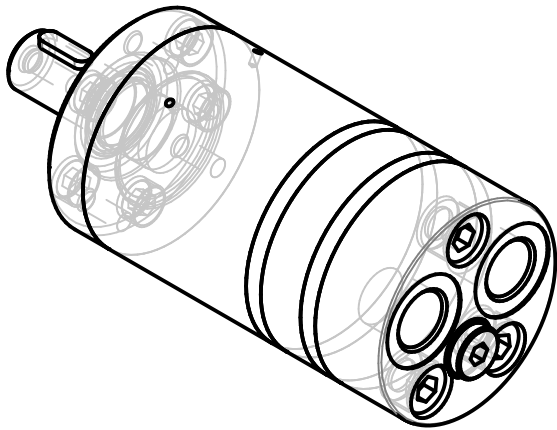

NOTE: Showed dimensions are in nominal, for maximal values see table.

NOTE: For additional dimensions and information about flange , shaft , endcover , etc. see next page.

L max	LS max
114	

Confidential property of M+S Hydraulic, Bulgaria.
Please note that this drawing is automatically generated based on the selection. In case of possible changes or revisions in the drawing specifications, the selection process should be repeat. M+S is not responsible for any possible errors on the drawings.



MM32CP

Design: M+S

Check:

Scale	Sheet	Rev.	Weight
Date 07.03.2024			2,2 [4.85]



Standard Rotation
Viewed from Shaft End

Port A Pressurized - CW
Port B Pressurized - CCW

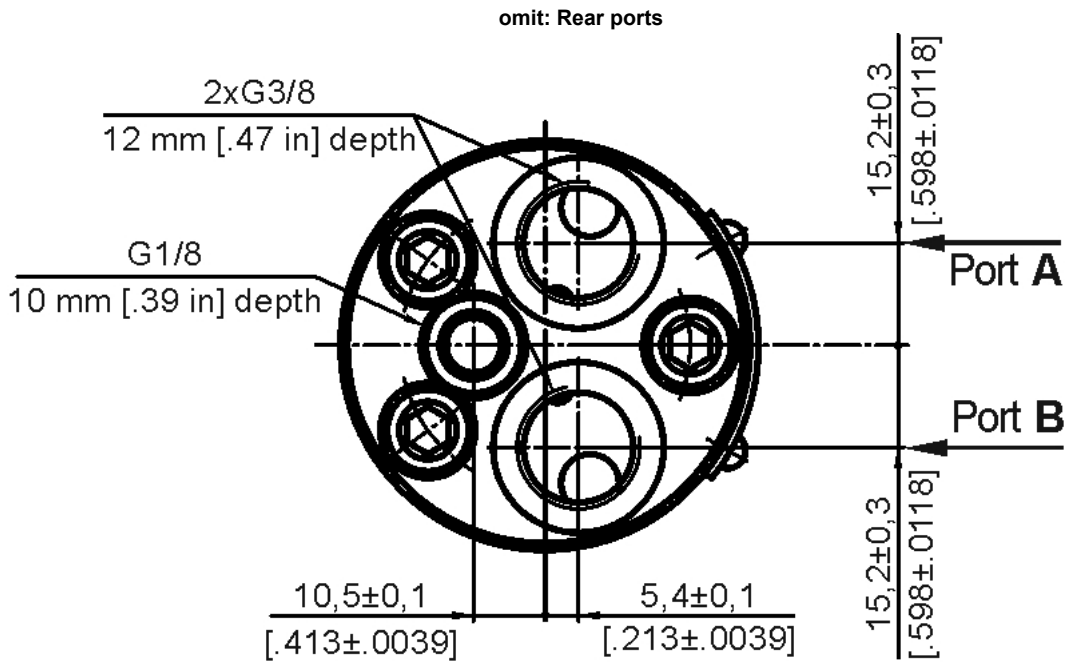
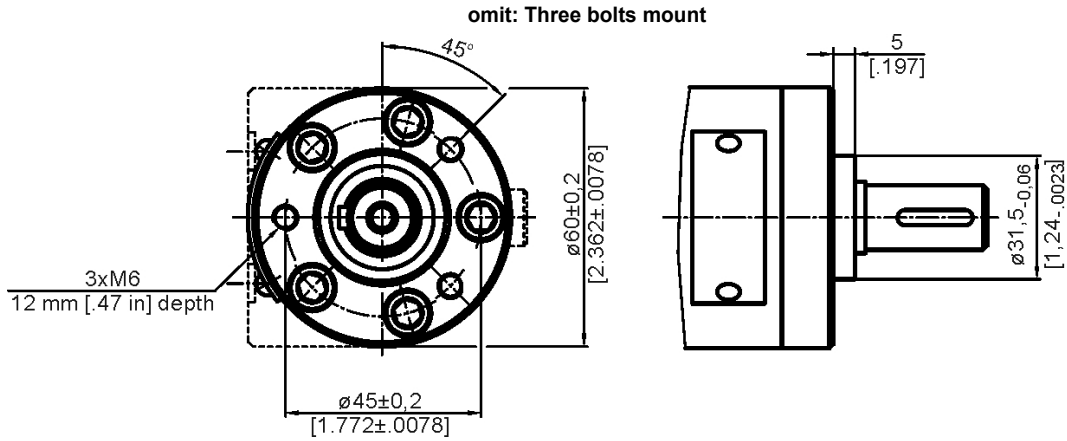

C: ø16 straight, Parallel key A5x5x16 DIN6885

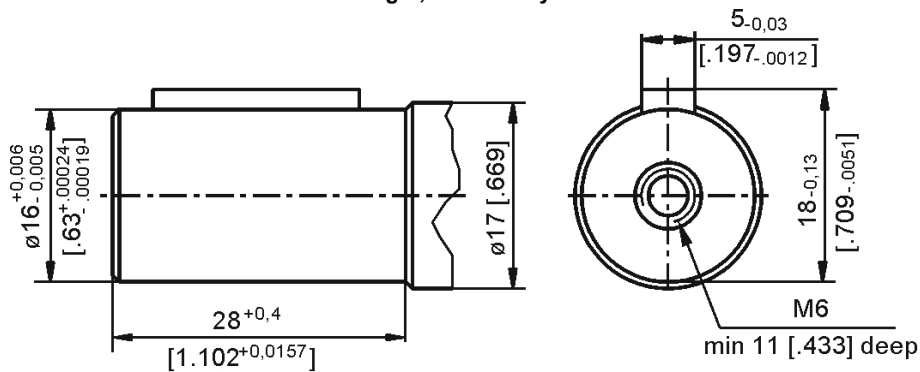

Confidential property of M+S Hydraulic, Bulgaria.
Please note that this drawing is automatically
generated based on the selection. In case of
possible changes or revisions in the drawing
specifications, the selection process should be
repeat.M+S is not responsible for any possible
errors on the drawings.



MM32CP

Scale	Sheet	Rev.	Weight
Date 07.03.2024			2.2 [4.85]

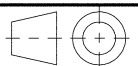

MM32CP

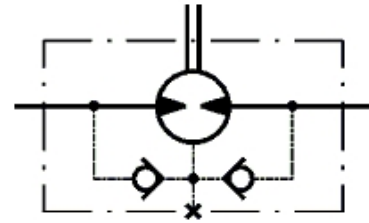

Hydraulic scheme with check valves

FUNCTION DIAGRAMS

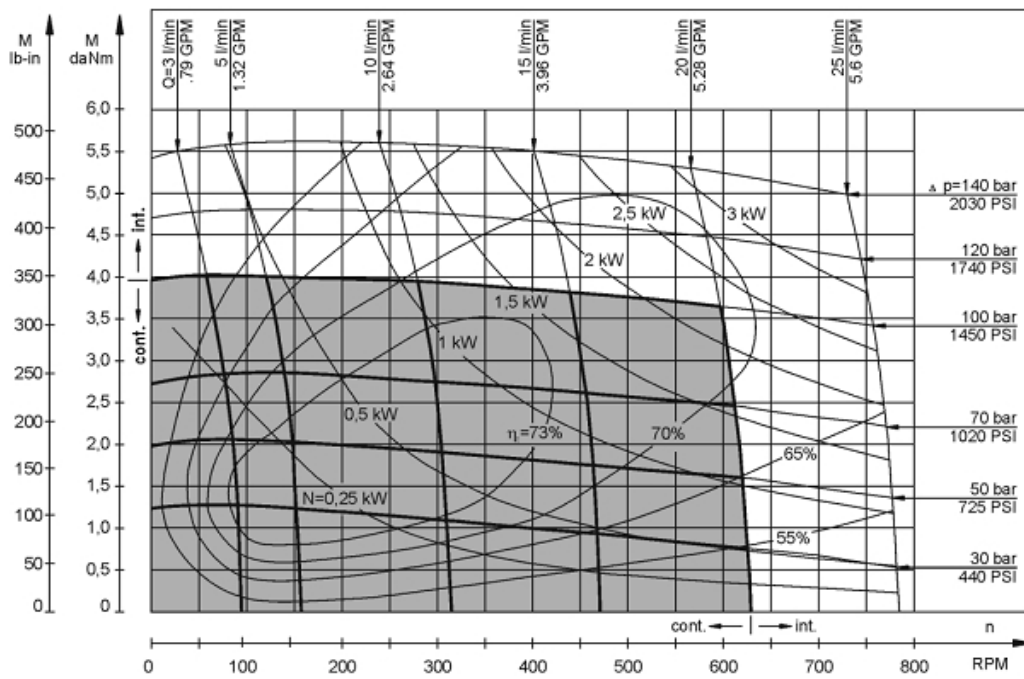

The function diagrams data is for average performance of randomly selected motors at back pressure 5÷10 bar [72.5÷145 PSI] and oil with viscosity of 32 mm²/s [150 SUS] at 50°C [122°F].

MM32CP

DATA SHEET

Pressure Losses

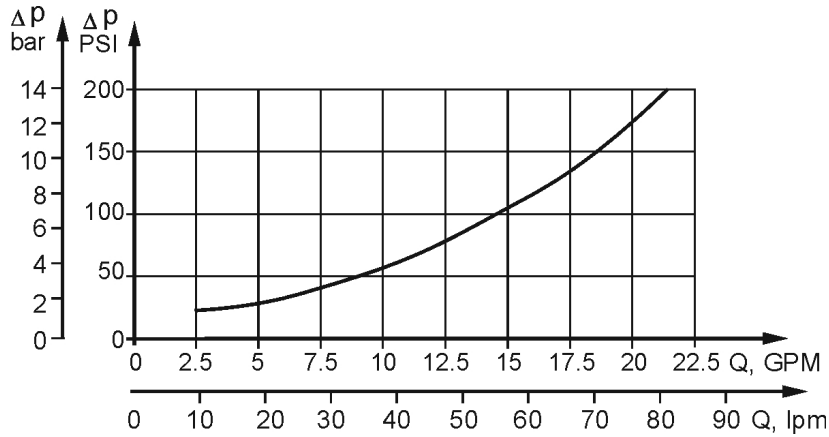

PERMISSIBLE SHAFT LOADS

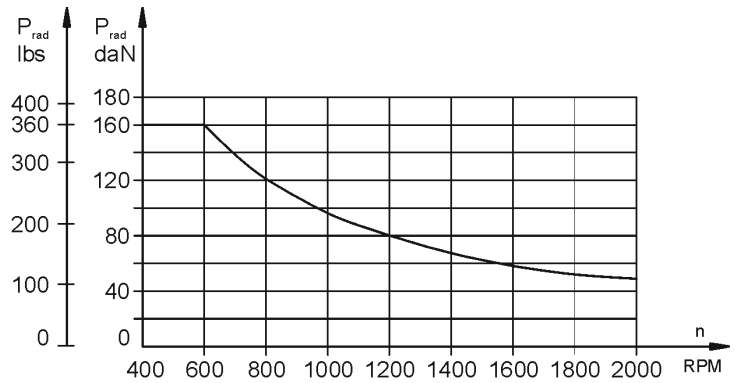
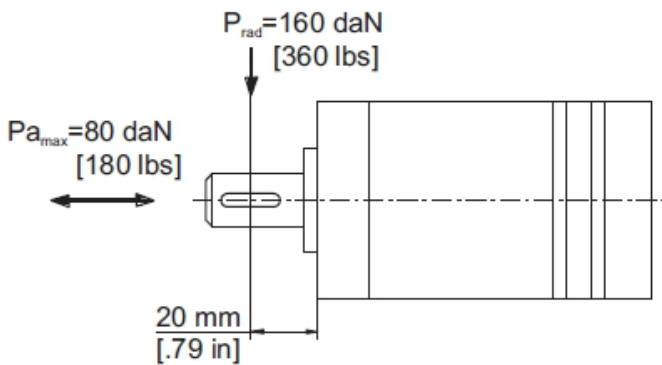

The chart shows the permissible radial load when L=20 mm [.79 in]. If the calculated shaft load exceeds the permissible one, a falexible coupling must be used.

For more detail information about premissible shaft load please check our full catalogue