

CONTINUOUS DUTY 3 PH AC MOTORS

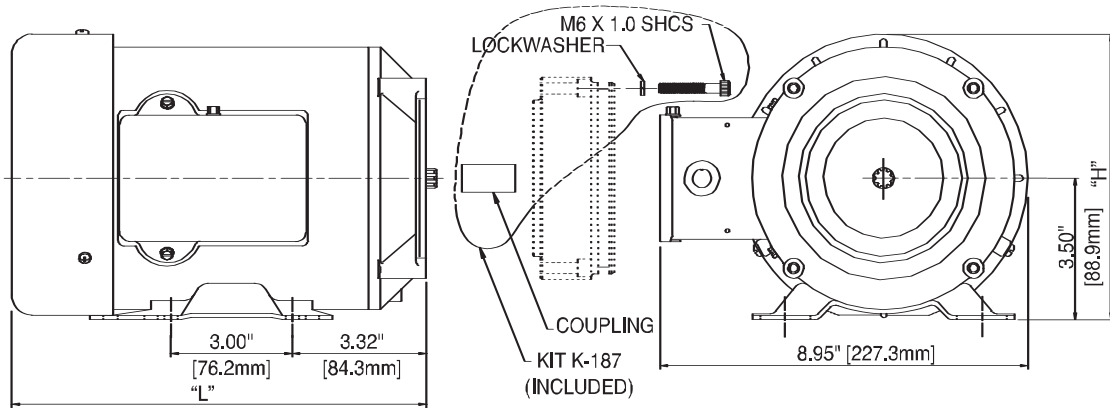

Motor Shaft	"L"	"H"
KMC18	10.38" [263.5mm]	7.04" [178.8mm]
KMC19	11.75" [298.5mm]	7.04" [178.8mm]
KMC20	12.48" [317.0mm]	8.74" [222.0mm]

Motor/Pump	KP8	KP10	KP12	KP16	KP20	KP25	KP31	KP40	KP50	KP63	KP80
KMC18 2 HP 3450 RPM, 3PH 230/460v 60Hz	.58 GPM 4300 PSI	.7 GPM 3450 PSI	.91 GPM 2850 PSI	1.3 GPM 2150 PSI	1.7 GPM 1700 PSI	2.2 GPM 1300 PSI	2.7 GPM 1000 PSI	3.5 GPM 750 PSI	4.4 GPM 500 PSI	NOT RECOMMENDED	
	2.3 LPM 300 BAR	2.7 LPM 240 BAR	3.5 LPM 200 BAR	5.1 LPM 150 BAR	6.6 LPM 115 BAR	8.4 LPM 90 BAR	10 LPM 70 BAR	14 LPM 50 BAR	17 LPM 35 BAR		
KMC19 3 HP 3450 RPM, 3PH 230/460v 60Hz	.56 GPM 5000 PSI	.62 GPM 5000 PSI	.83 GPM 4300 PSI	1.2 GPM 3200 PSI	1.6 GPM 2550 PSI	2.1 GPM 2000 PSI	2.6 GPM 1600 PSI	3.4 GPM 1200 PSI	4.3 GPM 900 PSI		
	2.2 LPM 350 BAR	2.4 LPM 350 BAR	3.2 LPM 300 BAR	4.8 LPM 225 BAR	6.4 LPM 175 BAR	8.2 LPM 140 BAR	10 LPM 110 BAR	13 LPM 80 BAR	17 LPM 60 BAR		
KMC20 5 HP 3450 RPM, 3PH 230/460v 60Hz	.56 GPM 5000 PSI	.62 GPM 5000 PSI	.79 GPM 5000 PSI	1.2 GPM 5000 PSI	1.5 GPM 4300 PSI	2.0 GPM 3400 PSI	2.5 GPM 2700 PSI	3.3 GPM 2050 PSI	4.2 GPM 1600 PSI		
	2.2 LPM 350 BAR	2.4 LPM 350 BAR	3.1 LPM 350 BAR	4.5 LPM 350 BAR	6.0 LPM 295 BAR	7.9 LPM 235 BAR	9.8 LPM 185 BAR	13 LPM 140 BAR	16 LPM 110 BAR		

Performance at 45 CST (200 SSU) and 90% mechanical efficiency. GPM's are U.S. values. All motors are totally enclosed, fan-cooled (TEFC).

Motors are continuous duty but cannot be used above their rated kilowatts, regardless of duty cycle and must have full voltage to achieve rated kilowatts.

For flows over 3 U.S. GPM (11 LPM), use 1413-AA filter.

Note: Stone uses a network of qualified suppliers to ensure availability. There are minor dimensional and cosmetic differences between vendor's products.