

Index	Description of change	Date	Editor
-	-	-	-
-	-	-	-
-	-	-	-
-	-	-	-
-	-	-	-

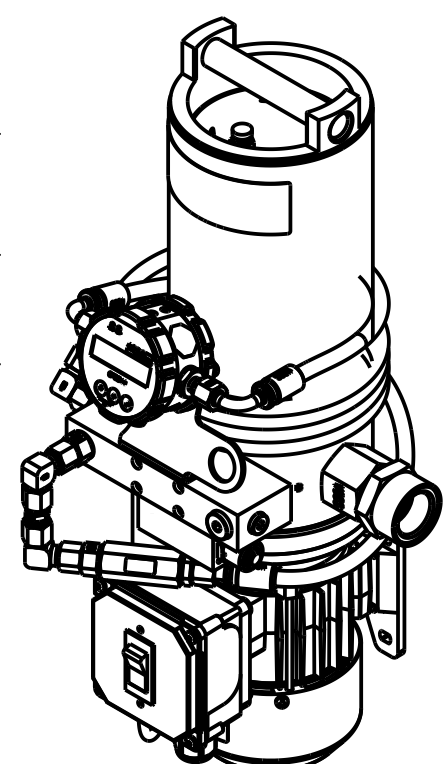
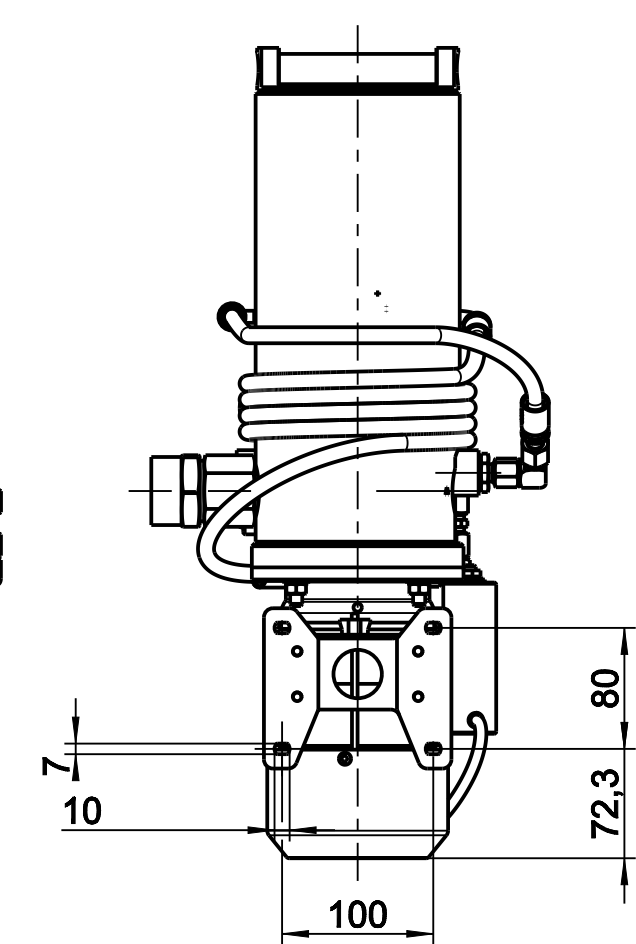
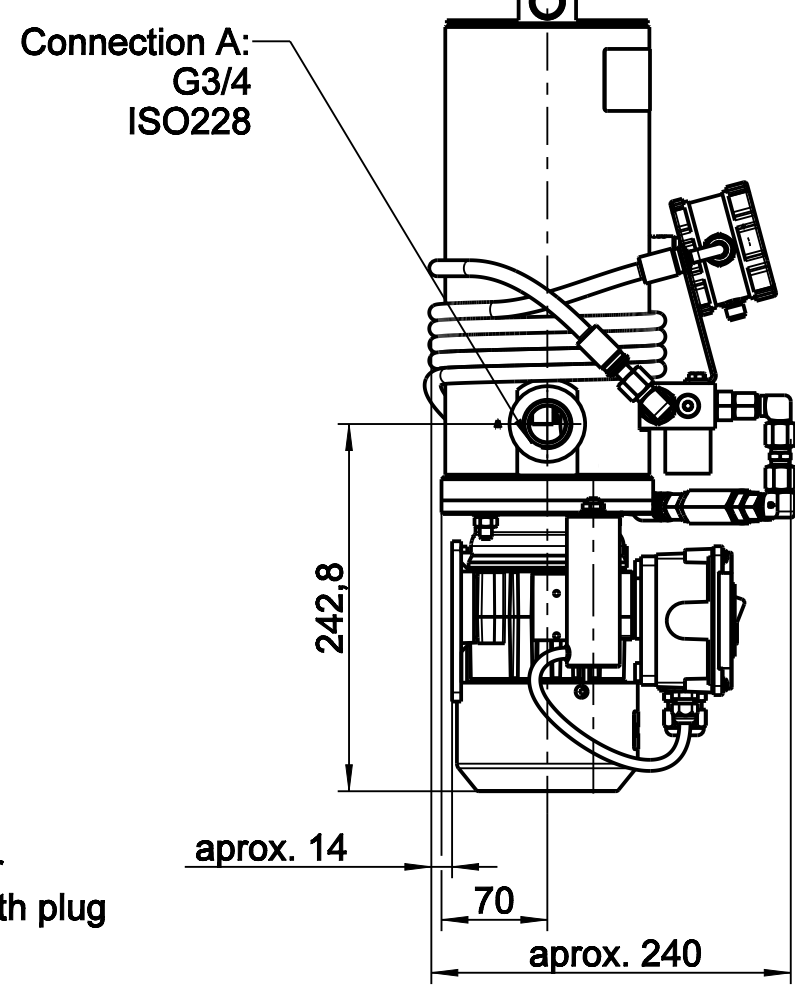
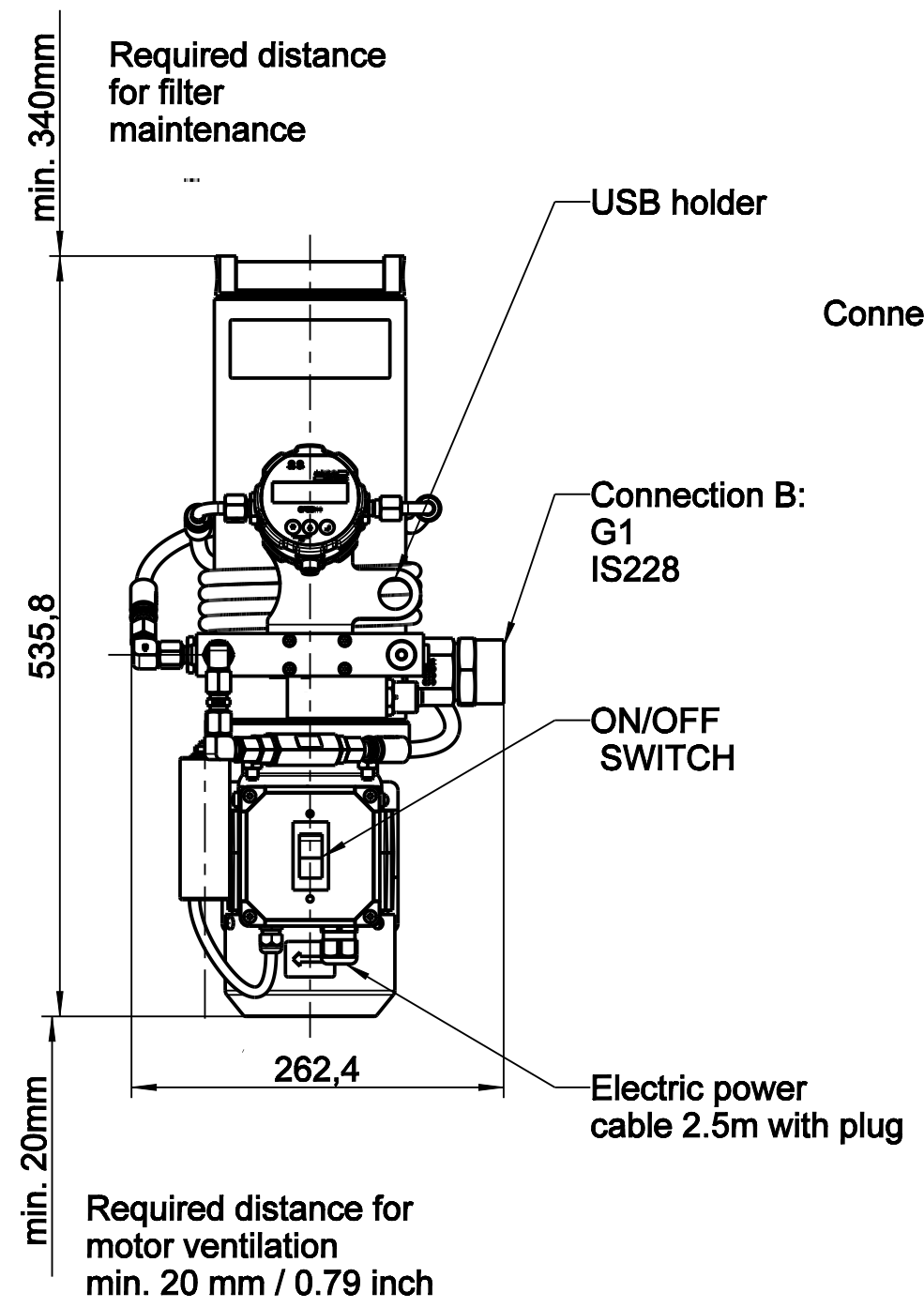

Protection notice ISO 16016

The reproduction, distribution and utilization of this document as well as the communication of its contents to others without express authorization is prohibited. Offenders will be held liable for the payment of damages. All rights reserved in the event of the grant of a patent, utility model or design.

In case of differences between the language versions, the ENGLISH version shall prevail

CAD produced drawing
No manual modification allowed

CUSTOMER DRAWING		Scale	1:5	Weight	14,4 kg
		Material	-	Dim. mm	Rough. -
		Name			
		OFF-LINE FILTER UNIT			
Date	21.03.2024	Order key	FNAPC1 008SGV005/23050-OD/C1		
Creator	j.madej	Material no.	46029100	Rev.	0 A3
Date	-	Substitute for	-		
Checker	-				Page 1/1
		ISO 8015			

Layout