

# Double check valve pilot-operated, sandwich type Z2S6

WN 6 |  $p_{max}$  35 MPa |  $Q_{max}$  60 dm<sup>3</sup>/min | WK 450 360



## DATA SHEET - OPERATION MANUAL

### APPLICATION

Double check valve, pilot operated, sandwich type **Z2S6...** is used for cutting off oil flow in one direction (with a possibility of controlling its opening) and opening free flow in the opposite direction. The valve is usually used for:

- unloading the valve that is under pressure
- preventing load drop in the event of a circuit break
- preventing creep movements of the blocked receivers.

The valve is used for sandwich mounting (inter-plate) in any working position.

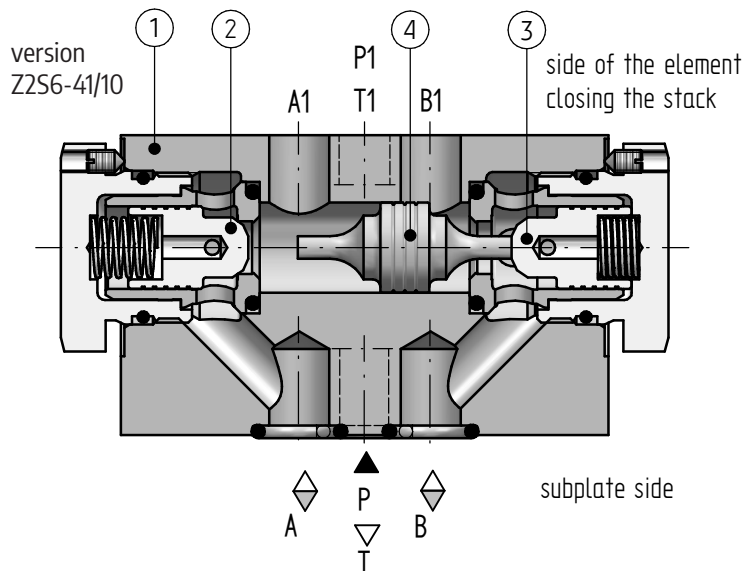
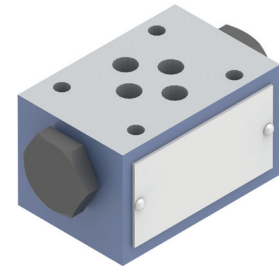

### EXAMPLE OF APPLICATION

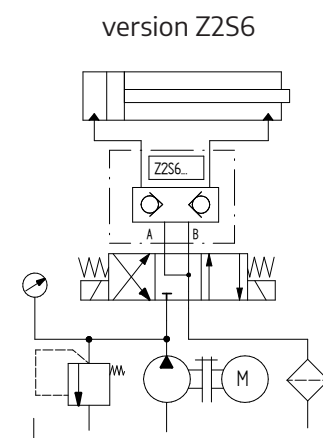

### DESCRIPTION OF OPERATION

Double check valve, pilot-operated type **Z2S6...** was made by fitting into one body **1** two pilot-operated check valves **2** and **3**. In the direction of flow from **A1** to **A** or from **B1** to **B** there is a free flow, but from **A** to **A1** or from **B** to **B1** the flow is closed. If there is a flow in the valve e.g. from **A1** to **A**, the piston **4** is moved to the right and pushes on the seat the pre-opening ball of the check valve **3**. Flow from **B** to **B1** is now open. The valve operates in a similar way at flow from **B1** to **B**. Pressure loss in lines **A1** or **B1** causes both valves to close. In order to obtain a safe and tight closure of both valves, the **A1** and **B1** lines must be connected with the drain.

### TECHNICAL PARAMETERS

hydraulic fluid, oil cleanliness class	mineral oil ISO 4406 class 20/18/15		
nominal fluid viscosity	37 mm <sup>2</sup> /s at temp. 55°C		
viscosity range	2,8 ÷ 380 mm <sup>2</sup> /s		
fluid temperature range (in tank)	recommended: 40 ÷ 55°C; max. -20 ÷ 70°C		
ambient temperature range	-20 ÷ 70°C		
max. working pressure, max. control pressure	35 MPa		
cracking pressure:	0,15 MPa	0,15 MPa	0,3 MPa
area ratio ( valve surface / piston surface )	1:2,97		
weight	0,8 kg		

assembly and operation requirements at: [www.operating-conditions.ponar.pl](http://www.operating-conditions.ponar.pl)

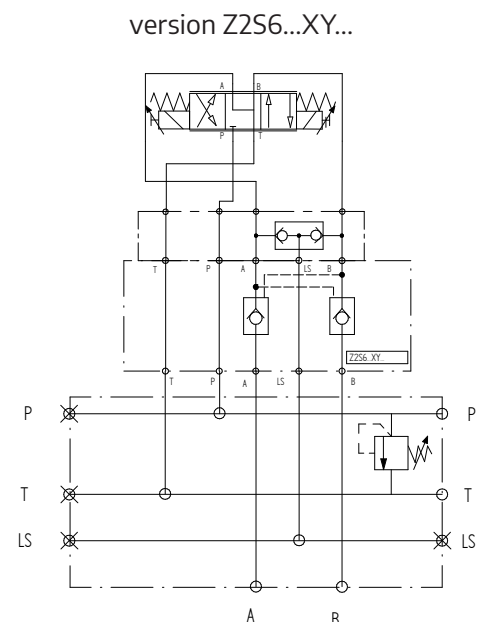

# HYDRAULIC DIAGRAMS

version Z2S6...

version Z2S6...A...

version Z2S6...B...

## simplified symbols

side of the element closing the stack

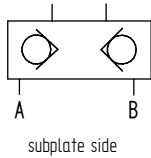

side of the element closing the stack

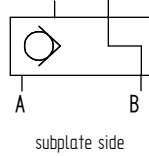

side of the element closing the stack

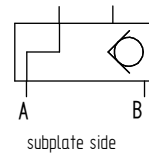

## detailed symbols

side of the element closing the stack

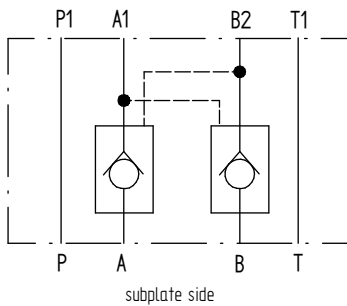

side of the element closing the stack

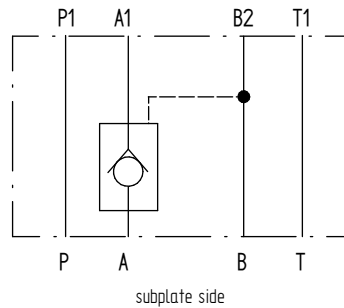

side of the element closing the stack

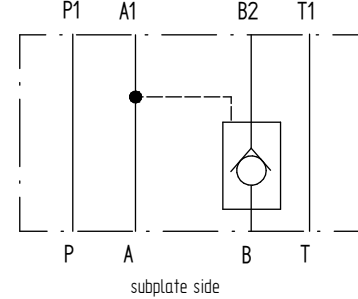

version Z2S6...XY...

side of the element closing the stack

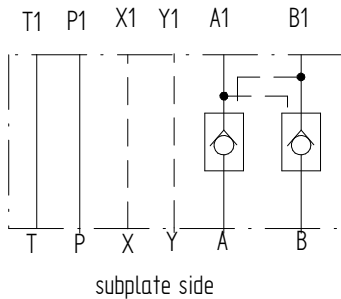

version Z2S6 A...XY...

side of the element closing the stack

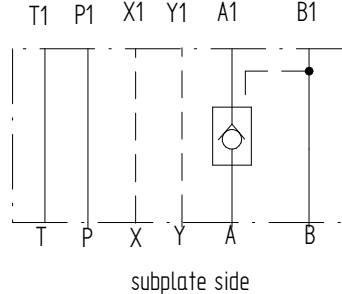

version Z2S6 B...XY...

side of the element closing the stack

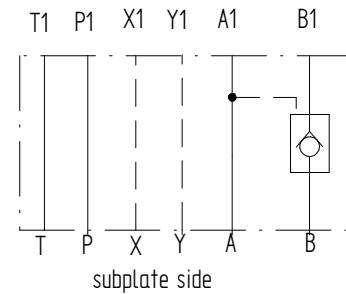

## PERFORMANCE CURVES

for fluid viscosity  $\nu = 41 \text{ mm}^2/\text{s}$  and temperature  $t = 50 \text{ }^\circ\text{C}$

### Flow resistance curves

performance curves  $p - Q$  of the check valve typ **Z2S6...**

flow direction	number of characteristic chart		
A1 → A / B1 → B	cracking pressure		
	0,1 MPa	0,15 MPa	0,3 MPa
	1	2	3
A → A1 / B → B1 (adjusted check valve)	4		

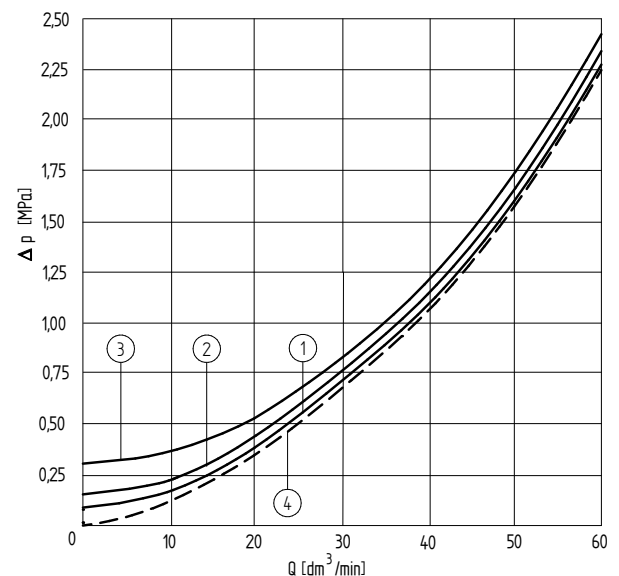

## OVERALL AND CONNECTION DIMENSIONS

### version Z2S6...

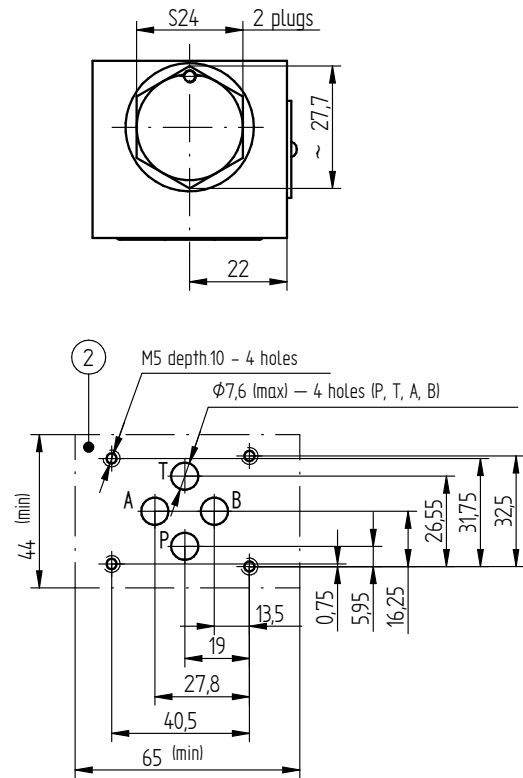
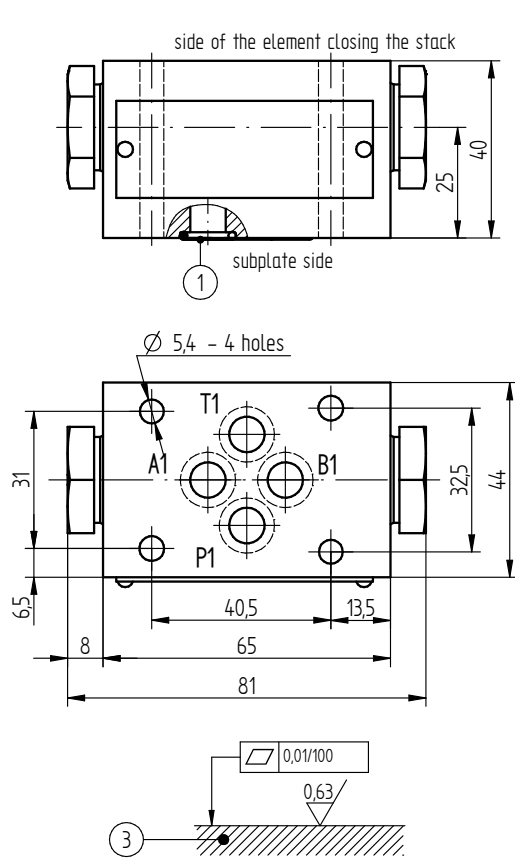

1. o-ring 9,2 x 1,8 - 4 pcs./set (P, T, A, B)
2. porting pattern of the subplate compliant with standards ISO 4401, designation ISO 4401-03-02-0-94 (CETOP 03)
3. required surface quality of the valve contact surface

### version Z2S6...XY...

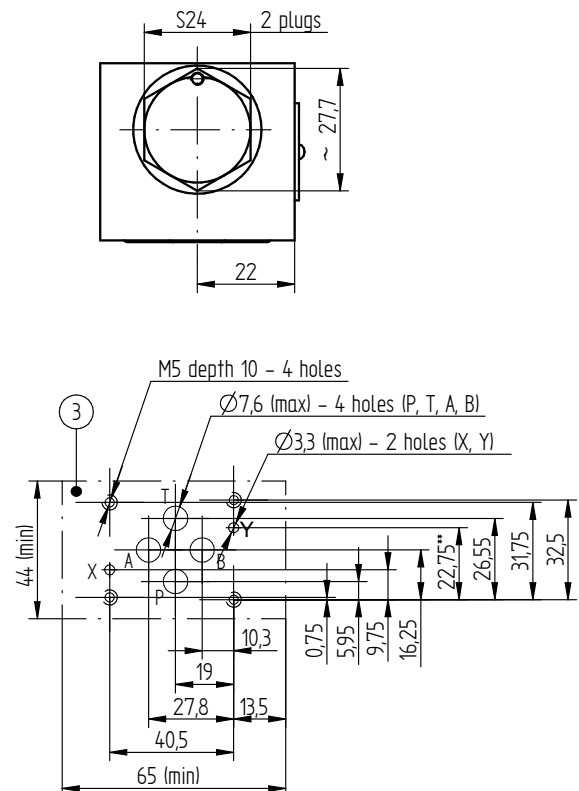
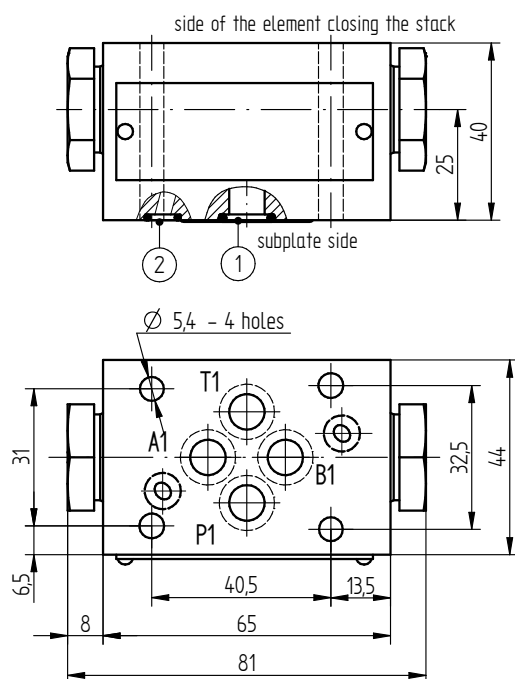

1. o-ring 9,2 x 1,8 - 4 pcs./set (P, T, A, B)
2. o-ring 4,87 x 1,8 - 2 pcs./set (X, Y)
3. porting pattern of the subplate compliant with standards ISO 4401, designation ISO 4401-03-03-0-94 (CETOP 03)
4. required surface quality of the valve contact surface

## HOW TO ORDER

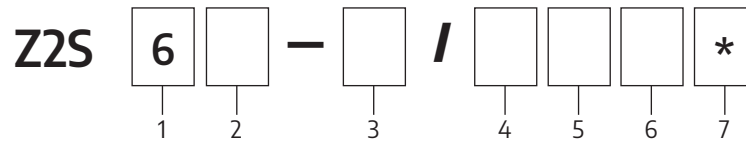

### 1 nominal size (NS)

NS6 = **6**

### 2 version with:

with two valves = **∅**  
 with a valve at port A = **A**  
 with a valve at port B = **B**

### 3 series number

series 41 = **41**  
 (40-49) connection and installation dimensions unchanged

### 4 cracking pressure

0,1 MPa = **10**  
 0,15 MPa = **15**  
 0,3 MPa = **30**

### 5 connection type

without ports X, Y = **∅**  
 with ports X, Y = **XY**

### 6 sealing type

NBR (for fluids based on mineral oils) = **∅**  
 FKM (for fluids based on phosphate esters) = **V**

### 7 further requirements = \*

(to be agreed upon with the Manufacturer)

∅ indicates that the box should be left blank.

The **symbols in bold** are the preferred versions available in short delivery time.

Coding example: **Z2S6 - 41/10**

## SUBPLATES AND MOUNTING SCREWS

Subplates must be ordered according to data sheet:

**WK 496 480**. Subplates symbols:

G 341/01 - threaded connections G 1/4

**G 342/01 - threaded connections G 3/8**

G 502/01 - threaded connections G 1/2

### NOTE:

Subplate symbols **in bold** indicate the preferred versions, available in short delivery time.

Subplates and mounting screws for mounting the valve:

**M5 × L\* - 10,9** acc. to **PN - EN ISO 4762 (PN/M-82302)** **4 pcs./set** delivered on a separate order.

Tightening torque of the screws **M<sub>d</sub> = 9 Nm**.

### NOTE:

(\*) - required length of L screws depends on the type and number of elements in the stack.

## KONTAKT

PONAR Wadowice S.A.  
 ul. Wojska Polskiego 29  
 34-100 Wadowice

tel. +48 33 488 21 00  
 www.ponar-wadowice.pl