

DHT Series

Digital Hydraulic Tester

The Digital Hydraulic Tester accurately measures oil flow, pressure and temperature and has a built-in loading valve to simulate the working pressure during normal machine operation.

The tester is ideal for reactive, proactive and preventive maintenance, designed to conveniently check the performance of hydraulic pumps, motors, valves and hydrostatic transmissions as well as for the setup of hydraulic attachments such as hammers and breakers.

DHTs are rugged, easy-to-use, bi-directional diagnostic testers with simplified controls. They comprise of a turbine flow block with loading valve, a large easy-to-read digital display which indicates both flow and temperature and a glycerine gauge to indicate pressure.

All DHTs feature Webtec's unique loading valve with built-in Interpass® safety protection, are sealed against dust and water jets and come with a five-year warranty as standard.

Specifications

Maximum Rated Pressure:	Up to 480 bar, 7000 psi
Maximum Rated Flow:	Up to 800 L/min, 210 US gpm
Fluid Temperature Range:	-10 to 125 °C, 14 to 257 °F
Ambient Temperature:	-10 to 50 °C, 14 to 122 °F
Compatible Fluid:	Mineral oils to ISO 11158. Other fluids consult sales office.
Accuracy:	
Flow:	Flow: ± 1 % full scale
Pressure:	± 1.6 % full scale
Temperature:	± 1 °C, ± 2 °F
Porting:	BSP, SAE
Material:	Case: Painted Mild Steel
	Flow Block: High Tensile Aluminium
	Seal: FKM
Battery Life:	Approximately 240 hours - Low power consumption

Make it **BLUE**®

Features

- Manufacturers 5 year warranty.
- Large display with selectable units.
- Sealed to IP65.
- Built-in loading valve.
- Bi-directional for unrestricted connection and simplified testing.
- Low power consumption – extended operation on standard battery.
- Portable and extremely robust.
- Interpass® safety protection system, bypasses oil internally in the event of the valve being over pressurised in either flow direction.



Sales Order Code

Please contact our technical sales team to discuss any special order requirements.

MODEL NUMBER	INLET/OUTLET PORTS	CALIBRATED FLOW RANGE		MAXIMUM RATED PRESSURE
		L/min	US gpm	
DHT03-B	1" BSPP	8 - 300	2 - 80	420 bar, 6000 psi
DHT03-S	1-5/16" -12UN #16 SAE ORB	8 - 300	2 - 80	420 bar, 6000 psi
DHT04-B	1" BSPP	10 - 400	2.5 - 105	420 bar, 6000 psi
DHT04-S	1-5/16" -12UN #16 SAE ORB	10 - 400	2.5 - 105	420 bar, 6000 psi
DHT08-S*	1-7/8" -12UN #24 SAE ORB	20 - 800	5 - 210	480 bar, 7000 psi
DHT08-S-L*	1-7/8" -12UN #24 SAE ORB	20 - 800	5 - 210	480 bar, 7000 psi

* Limited pressure control below 86 L/min (23 US gpm).

The maximum controllable pressure in this region is calculated by: max pressure (in bar) = 5 x flow (L/min) + 30

Installation Details

MODEL SERIES	A		B		C		D		WEIGHT	
UNITS	mm	in	mm	in	mm	in	mm	in	kg	lb
DHT03/04	222	8.74	202	7.95	181	7.13	110	4.33	6.5	14
DHT08	235	9.26	227	8.94	208	8.19	144	5.67	10	22

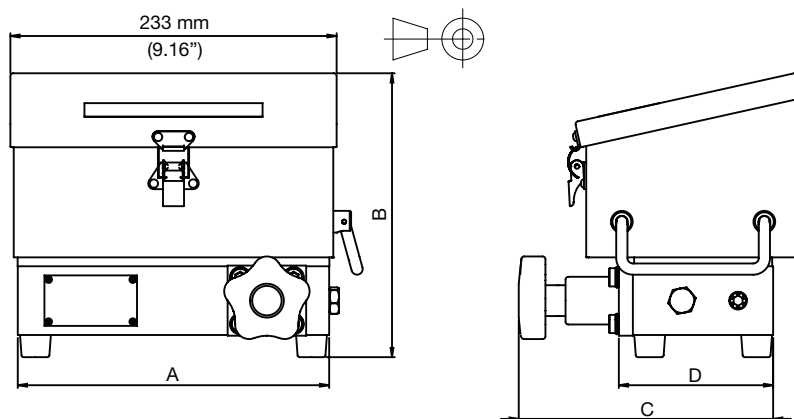

Operation

DHT testers are microprocessor-based instruments providing flexibility and high accuracy. Flow and Temperature are continuously displayed in different sized fonts on a large liquid crystal display. Flow and temperature units can be changed with the display panel buttons. Low power micro-circuitry and power management minimises battery consumption so a standard 9-volt battery, that is available worldwide, will typically supply > 6 months normal testing.

The turbine block is made from high tensile aluminium and houses a six-blade turbine rotating on a stainless steel bearing and shaft. Built-in flow straighteners reduce flow turbulence and allow accurate flow measurement in both directions.

The integral loading valve gives progressive pressure loading in either flow direction. Replaceable safety burst discs are part of Interpass® safety protection system and operate if maximum pressure is exceeded, relieving flow to the return line. Replacement safety discs are stored in an internal holder machined in the rear of the flow block.

There is an operational warning by a red LED if the electronics exceed maximum working temperature. This provides confidence in readings when measuring fluids up to 125 °C (257 °F).

Service and Calibration

All digital hydraulic testers are calibrated at a mean viscosity of 21cSt using ISO32 hydraulic mineral oil to ISO11158 category HM. A calibration certificate is supplied with each meter.

Recommended period between services is 12 months. Maximum period between services is 36 months. Unit accuracy may be affected by operating cycle, fluid condition or extended periods between services. Service reminders are displayed at power ON as a useful tool to help keep the meter safe and working within specification. The reminder looks like: **SEr** ³⁵/₃₆₅

Installation

It is recommended to connect the flow block with flexible hoses 1-2 metres (3-6ft) long. Inlet and outlet connections should always be of a similar bore size to that of the flow block to prevent venturi or constriction effects.

Where repetitive pulsation causes lateral pipe movement against the ports, we recommend the hoses are firmly clamped.

Filtration

Must be better than DIN ISO4406: 21/19/16 or NAS 10 (typically achieved with 20-25u filters).

Webtec® reserve the right to make improvements and changes to the specification without notice

Webtec®, Make it BLUE®, FlowHUB®, ViscoCorrect®, Interpass® and QuickCert® are registered trademarks of Webtec Products Limited.