

HYDRAULIC MOTOR BLOCKS TYPE BV

BVR .. 05 ..

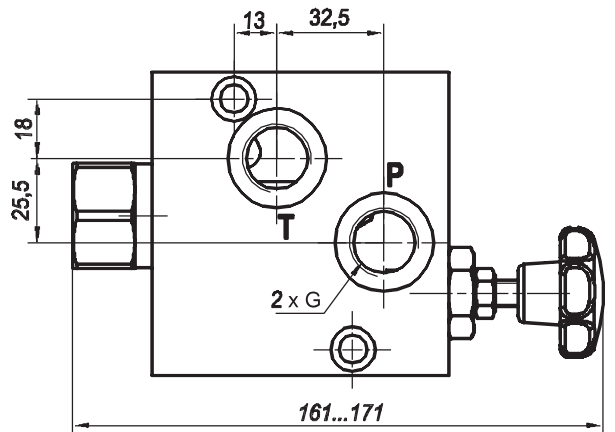
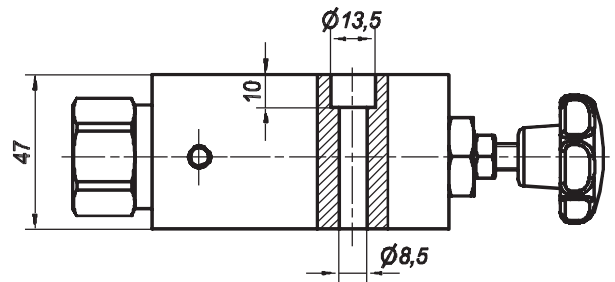
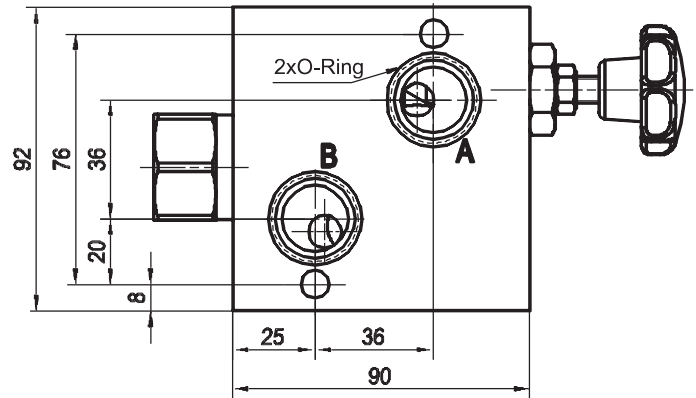
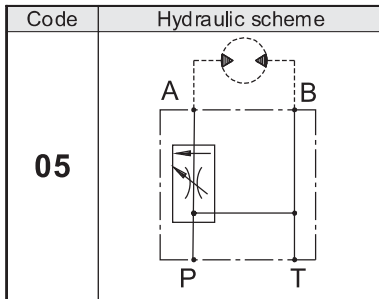

Type	Flow rate max. "P"	Rated flow "A"	P _{max.}	Port threads G	O-Ring
	L/min	L/min	bar	-	-
BVR 1205 ..	90	70	250	G1/2 - DIN 3852	23,6x2,65
BVR 7805 ..	90	70	250	7/8-14UNF - ISO 11926	26x2

ORDERING CODE

BV R 12 05 AL

