

Version	Symbol	Type
Unidirectional with female-female thread		V52
Bi-directional with female-female thread		V53
Unidirectional with push-in fitting		V54..U
Bi-directional with push-in fitting		V54..B
For cylinders with male thread on inlet and push-in fitting on outlet		V55..C
For valves with male thread on inlet and push-in fitting on outlet		V55..V



Series of in-line flow restrictors available with one direction (unidirectional) or 2 directions (bi-directional) control of the compressed air flow.

* How to order: V521414

Threads	1/8"	1/4"	3/8"	1/2"	M5
Code	18	14	38	12	M5

V52	14	14
Type	Tube or thread code	Tube or thread code

External tube (mm)	4	6	8
Code	04	06	08

Flow table at 6 bar (Nl/min)													
V52				V53				V54			V55		
1/8"	1/4"	3/8"	1/2"	1/8"	1/4"	3/8"	1/2"	04	06	08	04	06	08
450	600	1100	1400	210	300	500	500	140	250	400	100	250	400

Technical data				
	V52	V53	V54	V55
Fluid	Compressed filtered air with or without lubrication			
Pressure range	2 ÷ 10 bar		0,5 ÷ 10 bar	
Temperature range	0 °C ÷ 60 °C			
Threads	Parallel: UNI - ISO 228/1, Metric: ISO R / 262			
Connection tubes	According to the fitting used		Calibrated nylon, polyurethane and rilsan	
Tubes tolerances	-		± 0,05 mm	
Materials	Body: Anodised aluminium Needle: Nickel plated brass Seals: Nitrile rubber (NBR) Spring: Stainless steel		Body: Acetal resin Needle: Nickel plated brass Connections: Thread in nickel plated brass/ Push-in fitting Seals: Nitrile rubber (NBR) Spring: Stainless steel	

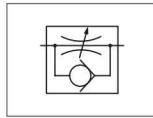
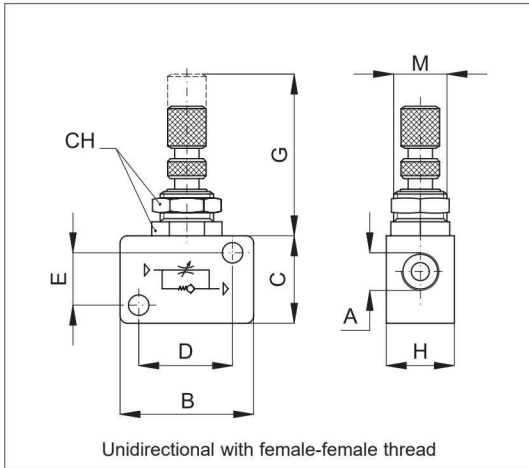

Unidirectional

Code	Item	A	B	C	H	D	E	F	G	M	H
030001	V521818	1/8"	32	22	17	23	13	4,5	35	M12	15
030002	V521414	1/4"	39	32	22	30	22	4,5	35	M12	15
030004	V523838	3/8"	56	42	27	43	27	6,5	43	M18	24
030005	V521212	1/2"	56	42	27	43	27	6,5	43	M18	24

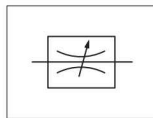
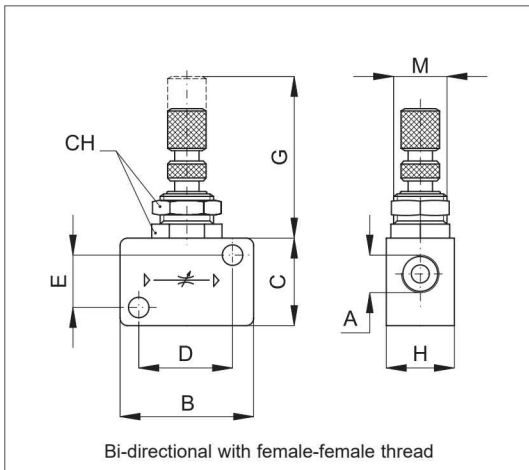

Bi-directional

Code	Item	A	B	C	H	D	E	F	G	M	H
030031	V531818	1/8"	32	22	17	23	13	4,5	35	M12	15
030032	V531414	1/4"	39	32	22	30	22	4,5	35	M12	15
030033	V533838	3/8"	56	42	27	43	27	6,5	43	M18	24
030034	V531212	1/2"	56	42	27	43	27	6,5	43	M18	24

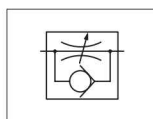
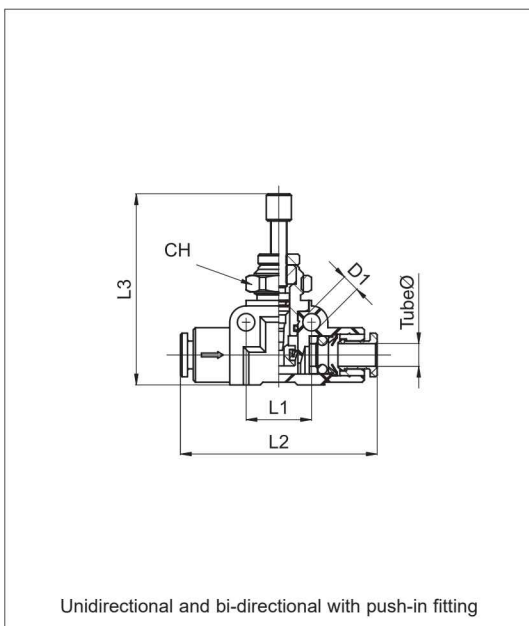

Unidirectional

Code	Item	Tube Ø	D ₁	L ₁	L ₂	L ₃ max	CH	gr.
030041	V540404U	4	3,2	13	35	35	11	14
030042	V540606U	6	3,2	16	45	45	14	26
030043	V540808U	8	3,2	16	46	46	14	28

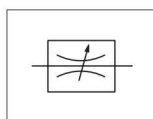

Bi-directional

Code	Item	Tube Ø	D ₁	L ₁	L ₂	L ₃ max	CH	gr.
030078	V540404B	4	3,2	13	35	35	11	14
030079	V540606B	6	3,2	16	45	45	14	26
030080	V540808B	8	3,2	16	46	46	14	28

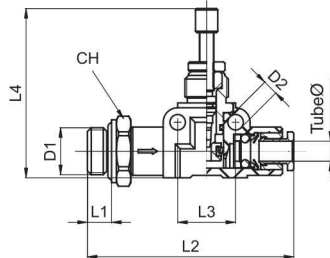

For cylinders and for valves with male thread on inlet and push-in fitting on outlet

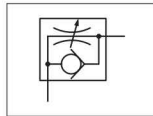

For cylinders

Code	Item	Tube Ø	D ₁	D ₂	L ₁	L ₂	L ₃	L ₄ max	CH	gr.
030045	V5504M5C	4	M5	3,2	4	43	15	35	9	17,5
030048	V550418C	4	1/8"	3,2	5	53	15	35	13	18
030047	V550618C	6	1/8"	3,2	5	52	15	45	13	32
030048	V550614C	6	1/4"	3,2	6,5	54	15	45	16	35
030049	V550818C	8	1/8"	3,2	5	53	15	46	14	35
030050	V550814C	8	1/4"	3,2	6,5	55	15	46	16	37

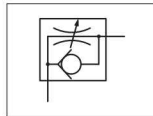

For valves

Code	Item	Tube Ø	D ₁	D ₂	L ₁	L ₂	L ₃	L ₄ max	CH	gr.
030045	V5504M5C	4	M5	3,2	4	43	15	35	9	17,5
030048	V550418C	4	1/8"	3,2	5	53	15	35	13	18
030047	V550618C	6	1/8"	3,2	5	52	15	45	13	32
030048	V550614C	6	1/4"	3,2	6,5	54	15	45	16	35
030049	V550818C	8	1/8"	3,2	5	53	15	46	14	35
030050	V550814C	8	1/4"	3,2	6,5	55	15	46	16	37